



# Aquila A 210

## Technische Daten • Specifications

### MOTOR

### ENGINE

	Bombardier Rotax 912 S3		
Zylinder	4		Cylinders
Leistung	100 PS • 100 hp		Power
TBO	2.000 Std. (oder 15 Jahre) • 2.000 h (or 15 years)		TBO

### PROPELLER

### PROPELLER

	mt-propeller MTV-21-A / 175-05 • Hydr. 2-Blade Constant-Speed •		
TBO	2.000 Std. • 2.000 h		TBO

### ABMESSUNGEN

### DIMENSIONS

Länge	7.3 m	24 ft	Lenght
Höhe	2.3 m	7.5 ft	Hight
Spannweite	10.3 m	33.8 ft	Wingspan
Flügelfläche	10.5 m <sup>2</sup>	113 sqft	Wing area
Kabinenbreite	1.2 m	47.2 in	Cabin width
Gepäckraumvolumen	500 l	18 cuft	Baggage compartment capacity

### MASSEN UND MENGEN

### WEIGHT AND CAPACITIES

Leermasse	500 kg	1,103 lb	Empty weight
Max. Flugmasse	750 kg	1.654 lb	Max. weight
Max. Zuladung	250 kg	551 lb	Max. load capacity
Max. Gepäckmasse	40 kg	88 lb	max. Baggage Weight
Max. Flächenbelastung	71.5 kg/m <sup>2</sup>	16.6 lb/sqft	max. Wing loading
Sitze	2		Seats
Kraftstoffvorrat	2 x 60 ltr	2 x 16 gal (US)	Fuel capacity
Kraftstoffart	100LL / EURO 95 (bleifrei - unleaded)		Fuelgrade

### FLUGLEISTUNGEN

### PERFORMANCE

Zul. Höchstgeschwindigkeit	305 km/h	165 kts	Max. permissible Speed
Max. Reisegeschwindigkeit (MSL)	240 km/h	130 kts	max. Cruise speed (MSL)
Min. Geschwindigkeit	80 km/h	43 kts	Min. Speed
Überziehgeschwindigkeit o. Klappen	93 km/h	50 ks	Stallspeed clean
Überziehgeschwindigkeit m. Klappen	80 km/h	43 kts	Stallspeed in landing configuration
Max. Seitenwindkomponente	28 km/h	15 kts	Max. demonstrated crosswind
Steiggeschwindigkeit (MSL)	3.8 m/s	750 ft/min	Climbrate (MSL)
Dienstgipfelhöhe	4.450 m	14.500 ft	Service ceiling
Max. Reichweite	1.150 km	620 NM	Max. range
Max. Flugdauer	6 Stunden 5 Minuten	6 hours 5 minutes	Endurance

*Fly emotion.*

## Abmessungen • Dimensions

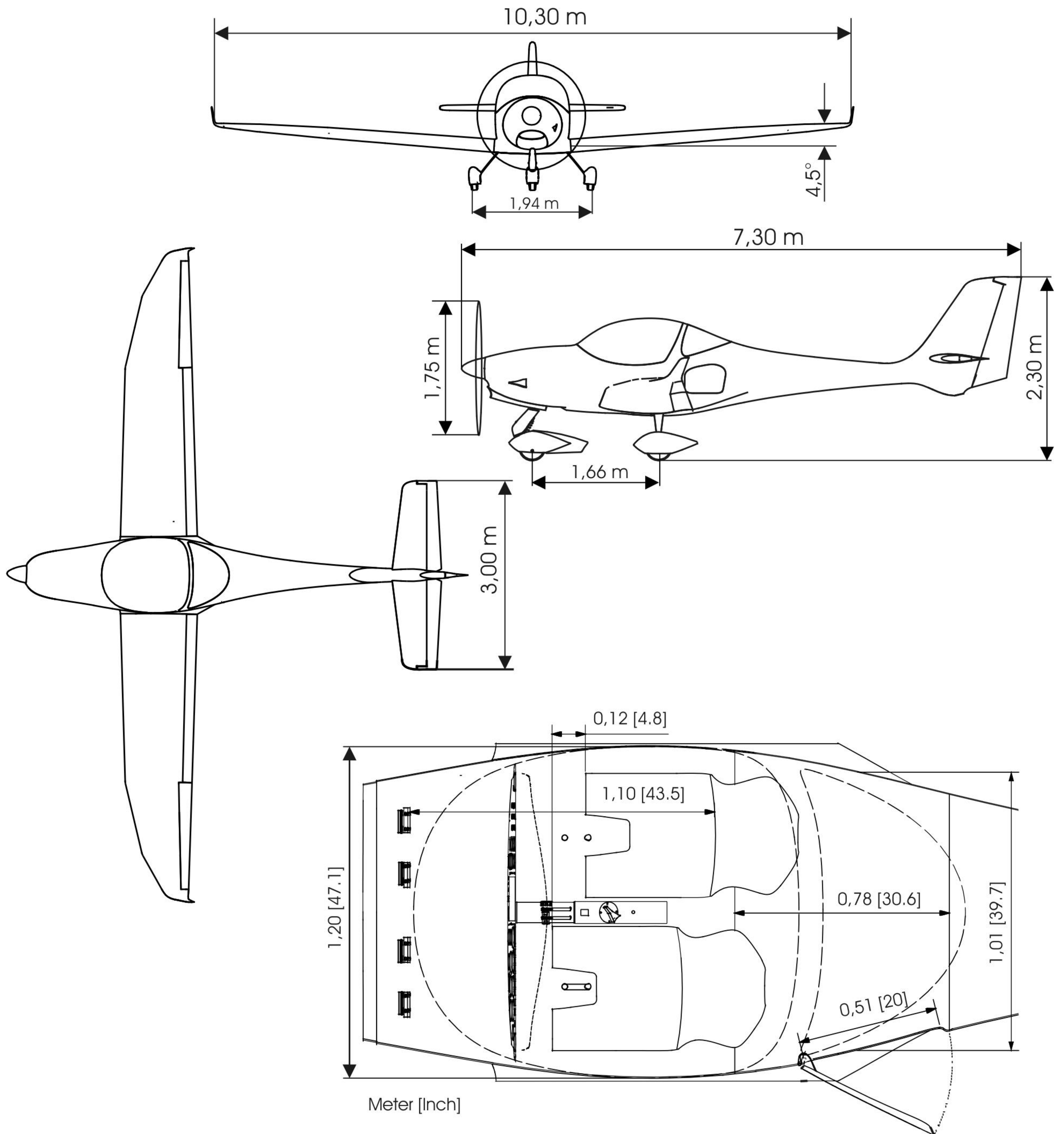

*Fly emotion.*